

# TB 9-6625-336-35

Change 2

---

**DEPARTMENT OF THE ARMY TECHNICAL BULLETIN**

---

**CALIBRATION PROCEDURE FOR  
FREQUENCY COMPARATOR, CM77 AND CM77A  
AND TRANSFER OSCILLATOR,  
HEWLETT-PACKARD, MODELS 540A AND 540B**

---

Headquarters, Department of the Army, Washington, DC  
27 July 1987

---

TB 9-6625-336-35, 11 April 1983, is changed as follows:

1. Removed old pages and insert new pages as indicated below. New or changed material is indicated by a vertical bar in the margin of the page.

**Remove pages**  
5 and 6

**Insert pages**  
5 and 6

2. File this change sheet in front of the publication for reference purposes.

By Order of the Secretary of the Army:

**JOHN A. WICKHAM, JR.**  
*General, United States Army*  
*Chief of Staff*

Official:

**R. L. DILWORTH**  
*Brigadier General, United States Army*  
*The Adjutant General*

Distribution:

To be distributed in accordance with DA Form 12-234C, Block No. 319, requirements for calibration procedures publications.

**PIN NO: 048340-002**

# TB 9-6625-336-35

Change 1

---

**DEPARTMENT OF THE ARMY TECHNICAL BULLETIN**

---

**CALIBRATION PROCEDURE FOR  
FREQUENCY COMPARATOR, CM77 AND CM77A  
AND TRANSFER OSCILLATOR,  
HEWLETT-PACKARD, MODELS 540A AND 540B**

---

Headquarters, Department of the Army, Washington, DC  
1 May 1984

---

TB 9-6625-336-35, 11 April 1983, is changed as follows:

1. Remove old pages and insert new pages as indicated below. New or changed material is indicated by a vertical bar in the margin of the page.

**Remove pages**  
5 and 6

**Insert pages**  
5 and 6

2. File this change sheet in front of the publication for reference purposes.

By Order of the Secretary of the Army:

**JOHN A. WICKHAM, JR.**  
*General, United States Army*  
*Chief of Staff*

Official:

**ROBERT M. JOYCE**  
*Major General, United States Army*  
*The Adjutant General*

Distribution:

To be distributed in accordance with DA Form 12-34C, Block No. 319, requirements for calibration procedures publications.

**PIN NO: 048340-001**

REPRINT INCLUDES CHANGES 1 AND 2.

# TB 9-6625-336-35

DEPARTMENT OF THE ARMY TECHNICAL BULLETIN

## CALIBRATION PROCEDURE FOR FREQUENCY COMPARATOR, CM77 AND CM77A AND TRANSFER OSCILLATOR, HEWLETT-PACKARD MODELS 540A AND 540B

Headquarters, Department of the Army, Washington, DC  
11 April 1983

### ◆ REPORTING OF ERRORS ◆

You can help improve this publication by calling attention to errors and by recommending improvements and stating your reasons for the recommendations. Your letter or DA Form 2028, Recommended Changes to Publications, should be mailed directly to Commander, U.S. Army Aviation and Missile Command, ATTN: AMSAM-TMD-EP, Redstone Arsenal, AL 35898-5000. FAX to DSN 788-2313 (commercial 256-842-2313). A reply will be furnished directly to you.

SECTION		Paragraph	Page
I.	IDENTIFICATION AND DESCRIPTION		
	Test instrument identification.....	1	2
	Forms, records, and reports .....	2	2
	Calibration description.....	3	2
II.	EQUIPMENT REQUIREMENTS		
	Equipment required .....	4	3
	Accessories required.....	5	3
III.	CALIBRATION PROCESS		
	Preliminary instructions .....	6	4
	Equipment Setup.....	7	4
	Oscillator frequency, stability and output .....	8	5
	Video amplifier .....	9	6
	Oscilloscope trace alignment .....	10	8
	Horizontal sweep .....	11	8
	Power sweep .....	12	9
	Final procedure.....	13	10

\*This bulletin supersedes TB 9-6625-336-35, 10 March 1981.

**SECTION I  
IDENTIFICATION AND DESCRIPTION**

**1. Test Instrument Identification.** This bulletin provides instructions for the calibration of Frequency Comparator CM77 and CM77A; and Transfer Oscillator, Hewlett-Packard Models 540A and 540B. The manufacturer's manuals and TM 11-6625-493-15 were used as the prime data sources in compiling these instructions. The equipment being calibrated will be referred to as the TI (test instrument) throughout this bulletin.

**a. Model Variations.** Described in text.

**b. Time and Technique.** The time required for this calibration is approximately 2 hours, using the dc and low frequency technique.

**2. DA Form 2416 (Calibration Data Card)**

**a.** Forms, records, and reports required for calibration personnel at all levels are prescribed by TB 750-25-1. DA Form 2416 must be annotated in accordance with TB 750-25-1 for each calibration performed.

**b.** Adjustments to be reported on DA Form 2416 are designated (R) at the end of the sentence in which they appear. When adjustments are in tables, the (R) follows the designated adjustment. Report only those adjustments made and designated with (R).

**3. Calibration Description.** TI parameters and performance specifications which pertain to this calibration are listed in table 1.

Table 1. Calibration Description

Test instrument parameters	Performance specifications
Line voltage regulation	115 or 220 V ac $\pm$ 10%, 50 to 1,000 Hz, 115 W
Oscillator Fundamental frequency: Range Output Stability Dial accuracy	100 to 200 MHz Approx. 2 V into 50 $\Omega$ < 0.002% change per minute after 30 minute warmup $\pm$ 0.5%
Amplifier: Gain Bandwidth Undistorted output (Max)	Adjustable to 40 dB max 100 Hz to 2 MHz 1 V rms usable signal across 1 k $\Omega$ load
Oscilloscope: Frequency range Vertical deflection sensitivity Horizontal sweep: External Internal	100 Hz to 200 kHz 5 mV rms per inch 1 V per in., 20 Hz to 5 kHz Power supply frequency with phase control

**SECTION II  
EQUIPMENT REQUIREMENTS**

**4. Equipment Required.** Table 2 identifies the specific equipment to be used in this calibration procedure. This equipment is issued with Secondary Transfer Calibration Standards Set AN/GSM-286 and AN/GSM-287. Alternate items may be used by the calibrating activity when the equipment listed in table 2 is not available. The items selected must be verified to perform satisfactorily prior to use and must bear evidence of current calibration. The equipment must meet or exceed the minimum use specifications listed in table 2. The accuracies listed in table 2 provide a four-to-one ratio between the standard and TI.

**5. Accessories Required.** The accessories listed in table 3 are issued as indicated in paragraph 4 above and are used in this calibration procedure. When necessary, these items may be substituted by equivalent items, unless specifically prohibited.

Table 2 Minimum Specifications of Equipment Required

Item	Common name	Minimum use specifications	Manufacturer and model (part number)
A1	AUTOTRANSFORMER	Range: 105 to 125 V ac Accuracy: $\pm 1\%$	General Radio, Model W10MT3AS3 (7910809)
A2	DIFFERENTIAL VOLTMETER	Range: 2 mV to 7 V ac; 215 to 250 V dc Accuracy: $\pm 1\%$	John Fluke, Model 887AB/AN (887AB/AN)
A3	FREQUENCY COUNTER	Range: 99.5 to 221.1 MHz Accuracy: $\pm 0.17\%$	Hewlett-Packard, Model 5345A (MIS-28754/1 Type 1)
A4	MULTIMETER	Range: 1.1 to 2.1 V ac at 100 to 200 MHz Accuracy: $\pm 7\%$	Hewlett-Packard, Model 410C(7910902)
A5	OSCILLOSCOPE	Risetime: 70 ns or less	Tektronix, Type R 5440 (MIS-28706/1 Type 1) w/plug-ins 5A48 (MIS-28706/3) and 5B42 (MIS-28706/4)
A6	OSCILLOSCOPE CALIBRATOR	Range: 2 kHz at 5 mV Risetime: 70 ns or less	Ballantine, Model 6126M (MIS-28714 Type 1)
A7	TEST OSCILLATOR	Range: 20 Hz to 5 kHz; 1 V rms min.	Hewlett-Packard, Model 652A (MIS-10224)
A8	VARIABLE ATTENUATOR	Range: 0 to 40 dB	RLC Electronics, Model A2648 (MIS-10263)

Table 3. Accessories Required

Item	Common name	Description (part number)
B1	ADAPTER	BNC T-type; 2 jacks, 1 plug (MS35173-274C)
B2	ADAPTER <sup>1</sup>	N plug to BNC jack (10519457)
B3	ADAPTER	BNC plug to N jack (10519458)
B4	ADAPTER	Hewlett-Packard, Model 11042A, 410B probe to N jack and N plug (8899531)
B5	CABLE <sup>2</sup>	30-in., RG-58/U; BNC plug terminations (7907467)
B6	TERMINATION	51-ohm load on BNC plug (7622749)
B7	TERMINATION	50-ohm feed-through; BNC plug to BNC jack (1 1048B)
B8	TEST LEAD	30-in., RG-68/U; double banana plug to probe and alligator clip (7911305)

<sup>1</sup>Two required.

<sup>2</sup>Three required.

**SECTION III  
CALIBRATION PROCESS**

**6. Preliminary Instructions**

**a.** The instructions outlined in paragraphs **6** and **7** are preparatory to the calibration process. Personnel should become familiar with the entire bulletin before beginning the calibration.

**b.** Items of equipment used in this procedure are referenced within the text by common name and item identification number as listed in tables 2 and 3. For the identification of equipment referenced by item numbers prefixed with A, see table 2, and for prefix B, see table 3.

**WARNING**

HIGH VOLTAGE is used or exposed during the performance of this calibration. DEATH ON CONTACT may result if personnel fail to observe safety precautions.

**NOTE**

Unless otherwise specified, verify the result of each test and, whenever the test requirement is not met, take corrective action before continuing with the calibration. Adjustments required to calibrate the TI are included in this procedure. Additional maintenance information is provided in TM 11 - 6625-493-15 or manufacturer's manual.

**NOTE**

When indications specified in paragraphs **8** through **11** are not within tolerance, perform the power supply check prior to making adjustments. After adjustments are made, repeat paragraphs **8** through **11**. Do not perform power supply check if all other parameters are within tolerance.

**NOTE**

Unless otherwise specified, all controls and control settings refer to the TI.

**7. Equipment Setup**

**NOTE**

Remove TI protective cover only if necessary to perform adjustments.

- a.** Connect TI to autotransformer (A1).
- b.** Connect autotransformer to a 115-V ac source and adjust for a 115-V ac output.

**c.** Set **HORIZ SWEEP INPUT** switch (located on rear panel) to **INT**.

**d.** Position controls as listed in (1) through (6) below:

(1) **VIDEO RESPONSE LOW FREQ** control fully cw.

(2) **VIDEO RESPONSE GAIN** control to midrange or as necessary for proper slope presentation.

(3) **VIDEO RESPONSE HIGH FREQ** control fully cw.

(4) **FREQUENCY MEGACYCLES** dial to **100**.

(5) **FINE VERNIER** control to midrange.

(6) **HORIZ GAIN** control fully cw.

**e.** Energize equipment and allow sufficient time for warmup and stabilization.

**8. Oscillator Frequency, Stability, and Output**

**a. Performance Check**

(1) Connect equipment as shown in figure 1, connection A. If frequency counter (A3) does not indicate between 99.500 and 100.500 MHz, perform **b** below.

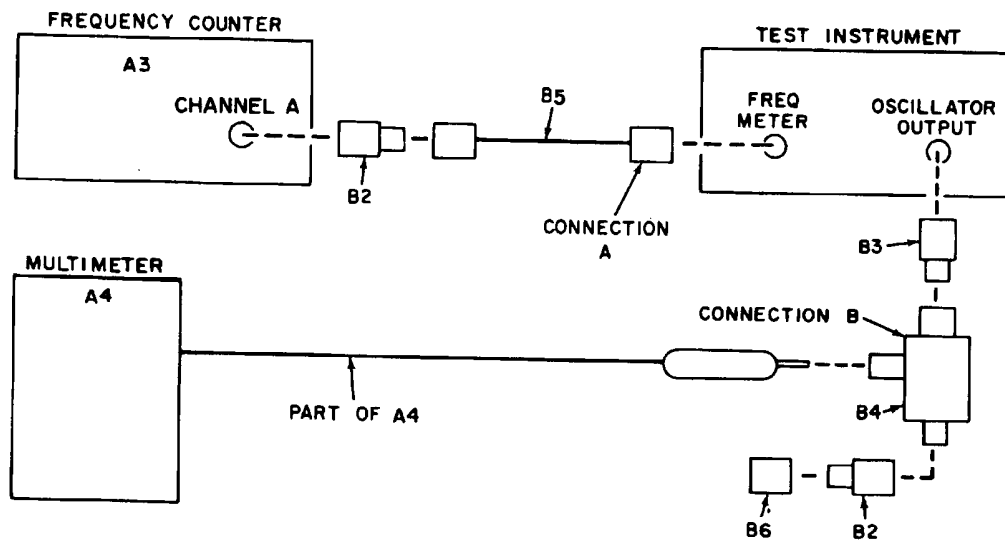

Figure 1. Oscillator frequency - equipment setup.

**TB 9-6625-336-35**

(2) Vary autotransformer (A1) output from 105 to 125 and back to 115 V ac while observing frequency counter. If frequency counter indication does not remain between 99.500 and 100.500 MHz, perform **b** below.

(3) Set **FREQUENCY MEGACYCLES** dial as listed in table 4. If frequency counter does not indicate within limits specified, perform **b** below.

Table 4. Oscillator Frequency

Test instrument <b>FREQUENCY</b> <b>MEGACYCLES</b> dial settings	Frequency counter indications (MHz)	
	Min	Max
110	109.45	110.55
120	119.40	120.60
130	129.35	130.65
140	139.30	140.70
150 <sup>1</sup>	149.25	150.75
160	159.20	160.80
170	169.15	170.85
180	179.10	180.90
190	189.05	190.95
200	199.00	201.00
210	208.95	211.05
220 <sup>2</sup>	218.90	221.10

<sup>1</sup>Monitor frequency counter for a period of 60 seconds. Frequency counter will not change by more than 3 kHz.

<sup>2</sup>Not on all models.

(4) Connect equipment as shown in figure 1, connection B.

(5) Rotate **FREQUENCY MEGACYCLES** dial throughout frequency range. Multimeter (A4) will indicate at least 2 V at its maximum voltage indication.

**b. Adjustments**

(1) Set **FREQUENCY MEGACYCLES** dial to **200**.

(2) Adjust C3 and C28 (fig. 2) for a 200-MHz indication on frequency counter (R).

**NOTE**

It may be necessary to adjust C3 and C28 for best compromise over entire frequency range.

**9. Video Amplifier**

**a. Performance Check**

(1) Connect oscilloscope calibrator (A6) **FAST RISE + OUTPUT** to oscilloscope (A5) vertical input, using two cables (B5) and variable attenuator (A8).



- (2) Adjust variable attenuator to 0 (zero) dB.

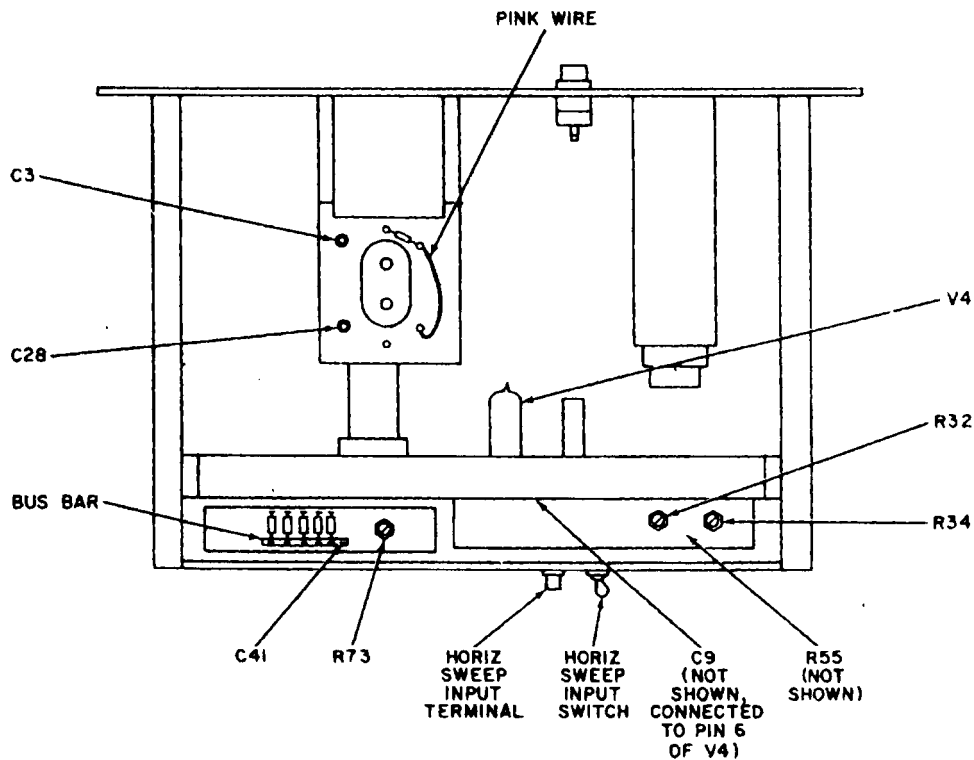

Figure 2. Transfer oscillator--top view.

- (3) Adjust oscilloscope calibrator frequency to 1 kHz and amplitude for a 0.5-V p-p indication on oscilloscope.
- (4) Adjust variable attenuator to 40 dB.

**NOTE**

Do not adjust oscilloscope calibrator amplitude.

- (5) Connect equipment as shown in figure 3.
- (6) Oscilloscope waveform will have a risetime no greater than 0.22  $\mu$ s, overshoot less than 25 percent, droop less than 10 percent, and amplitude of at least 0.5 V p-p. If overshoot is not within tolerance perform **b** below,
- (7) Adjust **FOCUS** and **INTENSITY** controls for suitable display and adjust **HORIZ GAIN** control for approximately 1 inch of horizontal deflection. Vertical deflection will be at least half the diameter of the crt.

**b. Adjustments.** Bend leads of C9 with respect to pins 1 and 2 of V 4 (fig. 2), until overshoot is less than 25 percent.

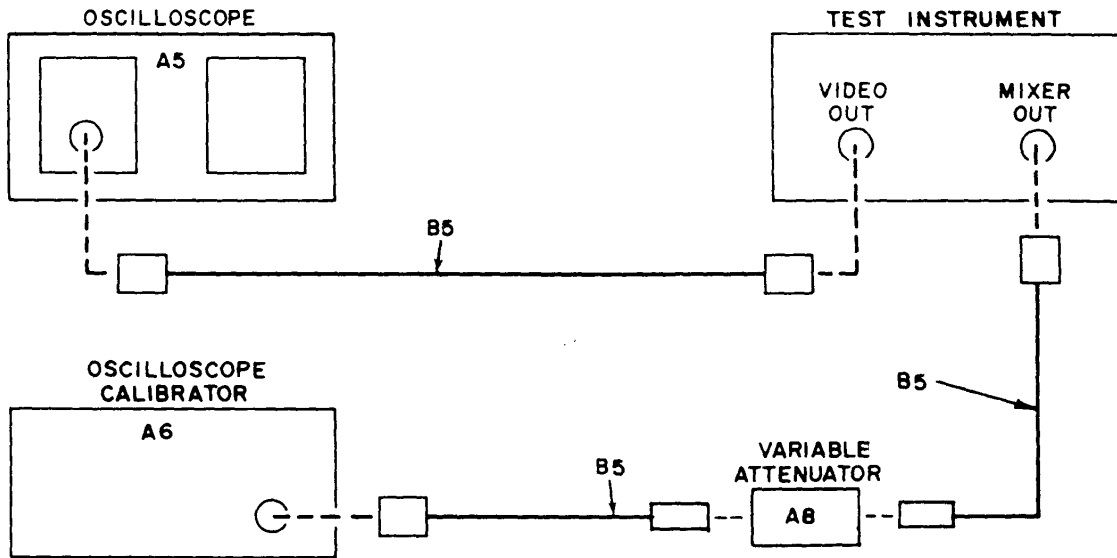

Figure 3. Video amplifier - equipment setup.

## 10. Oscilloscope Trace Alignment

### a. Performance Check

- (1) Disconnect input signal from TI.
- (2) Adjust oscilloscope **HORIZ GAIN** control for maximum horizontal deflection of trace with both edges of trace visible on oscilloscope. If trace is not centered both vertically and horizontally, perform b below.

### b. Adjustments (fig. 2)

- (1) Adjust R32 to center trace horizontally (R).
- (2) Adjust R34 to center trace vertically (R).

## 11. Horizontal Sweep

### a. Performance Check

- (1) Connect equipment as shown in figure 4.
- (2) Set **HORIZONTAL SWEEP INPUT** switch (rear of TI) to **EXT** and rotate **HORIZ GAIN** control fully cw.
- (3) Adjust test oscillator (A7) frequency to 1 kHz and amplitude for a 2.83 V p-p indication on oscilloscope (A5).

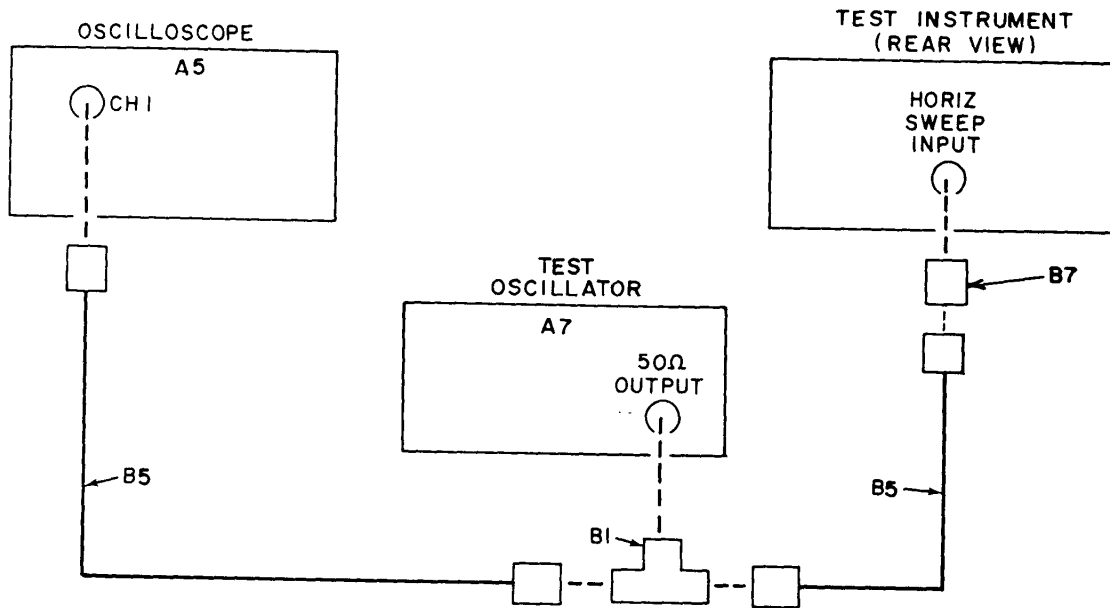

Figure 4. Horizontal sweep - equipment setup,

(4) Maintain 2.83 V p-p reference on oscilloscope for (5) below. Horizontal deflection on TI will not be less than one-half diameter of oscilloscope display.

(5) Repeat (3) above at frequencies of 20 Hz, 200 Hz, 2 kHz, and 5 kHz.

**b. Adjustments.** No adjustments can be made.

## 12. Power Supply

### a. Performance Check

#### NOTE

Do not perform power supply check if all other parameters are within tolerance.

(1) Connect differential voltmeter (A2) between ground and junction of C41 and bus bar (fig. 2), using test lead (B8). If voltmeter does not indicate between 231 and 249 V dc for Models 540B, CM77, and CM77A, except models with serial number between 129-00101 and 129-00597; or between 216 and 234 V dc for Models 540A and 540B with serial number between 129-00101 and 129-00597, perform **b**(1) below.

(2) Vary autotransformer (A1) output between 105 and 125 V ac and repeat (1) above.

(3) Adjust autotransformer for a 115-V ac output.

## **TB 9-6625-336-35**

(4) Adjust differential voltmeter to measure ac voltage. Differential voltmeter will indicate less than 5 mV rms.

(5) Connect differential voltmeter between ground and pink wire (fig. 2), using test lead (B8). If differential voltmeter does not indicate between 5.6 and 6.0 V rms for Models 540B, CM77, and CM77A; or between 5.8 and 6.2 V rms for Model 640A, perform b(2) below.

### **b. Adjustments (fig. 2)**

(1) Adjust R73 for a differential voltmeter indication of 240 V dc for Models 540B, CM77, and CM77A; or 225 V dc for Model 540A.

(2) Adjust R55 for a differential voltmeter indication of 5.8 V rms for Models 540B, CM77, and CM77A; or 6.0 V rms for Model 540A (R).

## **13. Final Procedure**

**a.** Deenergize and disconnect all equipment and reinstall TI protective cover.

**b.** When all parameters are within tolerance, annotate and affix DA Label 80 (US Army Calibrated Instrument). When the TI receives limited or special calibration, annotate and affix DA Label 163 (US Army Limited or Special Calibration). When the TI cannot be adjusted within tolerance, repair the TI in accordance with the maintenance manual. When repair is delayed for any reason or the TI cannot be repaired with local resources, annotate and affix DA Form 2417 (US Army Calibration System Rejected Instrument) and inform the owner/user accordingly in accordance with TB 750-25-1.

**TB 9-6625-336-35**

By Order of the Secretary of the Army:

**E. C. MEYER**  
*General United States Army*  
*Chief Of Staff*

**Official:**

**ROBERT M. JOYCE**  
*Major General United States Army*  
*The Adjutant General*

Distribution:

To be distributed in accordance with DA Form 12-34C, Block 319, requirements for calibration procedures publications.

US GOVERNMENT PRINTING OFFICE: 1983 - 646-027/1145

**PIN NO: 048340-000**